

AERO®

PRODUCT INFORMATION

EN - 01/26

 **RENSON®**

TABLE OF CONTENTS

Description	3
Benefits	4
Design	4
Design	4
Customisation	5
Comfort	5
Technical details	6
Standard configuration	7
Aero > 6055 - 7000 mm	8
Aero Infinity	9
Aero weight	10
Aero snow load	11
Accessoires	13
Certificates & Testing	15
Determination of occurring forces	16
Configuration	17
Type	17
Construction method	17
Dimensions	18
Profiles	21
Motor control	22
Blade orientation	23

Installation	24
Water drainage	26
Installation	30
Other tools	36



DESCRIPTION



A horizontal, water-repellent sun protection roof with rotatable blades that can be integrated perfectly into new or existing structures.

- Can be controlled using io, RTS or Renson® Connect App
- Minimalist and sleek design for subtle integration
- Matches all architectural styles
- Customised with millimetre precision
- Protection from the sun, rain and wind

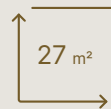

1 Roof section

BENEFITS

Design



1 MINIMALIST DESIGN

2 INVISIBLE SCREWS

Create an elegant and sleek structure

3 MINIMAL GAPS BETWEEN THE BLADES

Lend a stunning and sleek finish

Design

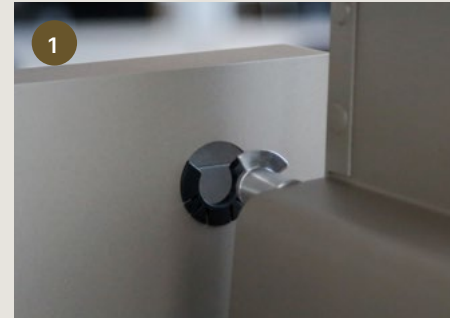

1 F2 TECHNOLOGY

INNOVATION

Every blade is secured to the frame to create a strong and stable structure

2 SPLASH PREVENTION

Via integrated water channels with diffusers

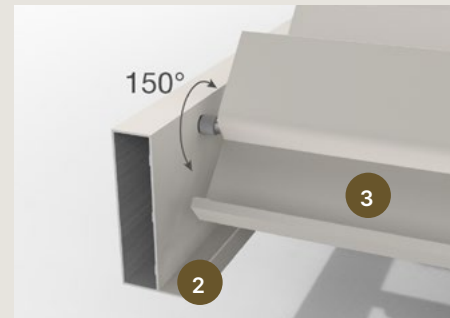

3 HIGH WATER DRAINAGE FLOW

Through the wide blade gutters

4 DOUBLE-WALLED BLADES FOR EXTRA STRENGTH

Load-bearing capacity: 100 kg/m²

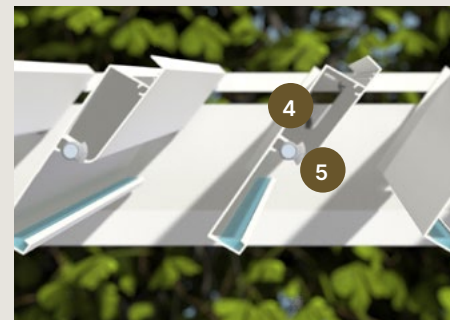

5 WELDED ALUMINIUM DRIPS, POWDER COATED TO MATCH THE COLOUR OF THE ROOF BLADES

6 UNIQUE END CAPS PROVIDE STRONG CORNER JOINTS

Customisation

For more information about the possible accessories, see the 'Accessories' section and/or the product information for the various accessories.

Comfort

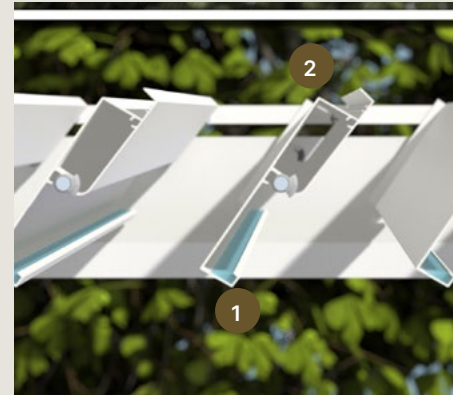

1 SPECIALLY DEVELOPED GUT-TER BORDER

INNOVATION

Prevents your patio and furniture from getting wet when the blades are opened following a rain shower

2 SILENT AND SOFT CLOSING MECHANISM BY ADDING A BRUSH TO THE BLADES

3 QUICK INSTALLATION

Thanks to maximum pre-assembly and the modular structure of the various junctions

4 MAXIMUM NATURAL LIGHT

Blades open through 150°

TECHNICAL DETAILS



Aero® - Technical Details

Dimensions	
Span – Single	Min. 1800* mm – max. 4500 mm
Span – Single with additional beam	Min. 1800* mm – max. 6000 mm
Span - Infinity	Min. 1800* mm – max. 4500 mm
Pivot	Min. 2615* mm – max. 7000** mm
Pivot - Infinity	Min. 7001 mm – max. 13500 mm***
Passage height	N/A
Total height with blades closed	230 mm
Total height with blades 90° open	230 mm + 95 mm
Blade rotation	Max. 150°
Customisation	Span and pivot: mm precision
Minimum number of water drainage points < 16 m ²	1
Minimum number of water drainage points > 16 m ²	2
Operating methods	
Renson® Connect App	✓
Somfy io	✓
Somfy RTS	✓
Home automation ready	✓

* Smaller dimensions (span min. 800 mm and pivot min. 1110 mm) possible by special request to pre-sales - drawing office.

** Pivot > 6055 - 7000 mm possible under certain conditions. See chapter 'Aero > 6055 - 7000 mm'.

*** Aero infinity = Aero with pivot > 7000 mm. Is possible given some conditions. See chapter 'Aero infinity'.

Electrical bladed roof drive

Parameters	Value
Supply voltage	230 Volt AC, 50 Hz
Transformer current range	0 – 2.5 Ampère
Transformer power	100 W
Motor voltage	24 Volt DC
Motor nominal current	3 Ampère
Protection rating	IP 66 Dynamic
Maximum running time with continuous use	Approx. 2 minutes
Automatic	16 A Curve C

Standard configuration



Construction

- Roof structure to be placed on top of or to be integrated in an existing support structure
- Custom span to the mm and pivot per blade step or to the mm
- Motor drive with choice of motor position and drainage
- Blade orientation (sun protection or maximum sunlight)

Finish

- Seaside Quality A
- Monocolour or dual colour according to Renson standard colours
- Integrated water drainage (incl. anti-splash diffusers in the gutter)

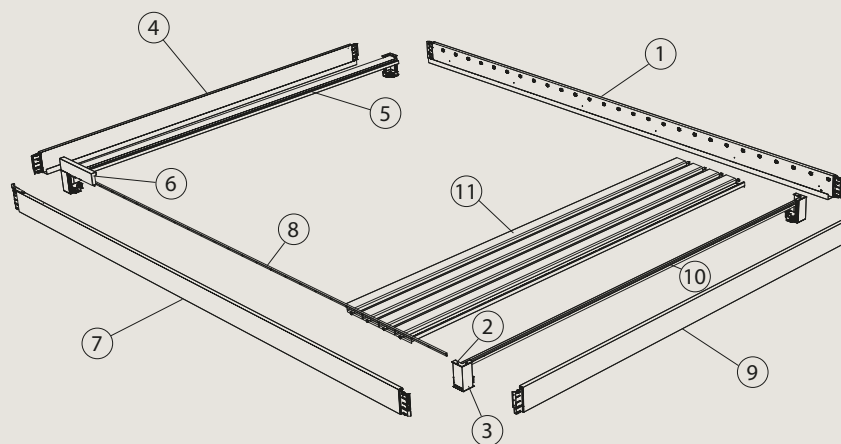

1	Pivot beam 1
2	Top cover
3	Inner cover
4	Span beam 2
5	Fixed blade
6	Motor + cover
7	Pivot beam 2
8	Driving profile
9	Span beam 1
10	Sealing profile
11	Blade

Aero > 6055 - 7000 mm

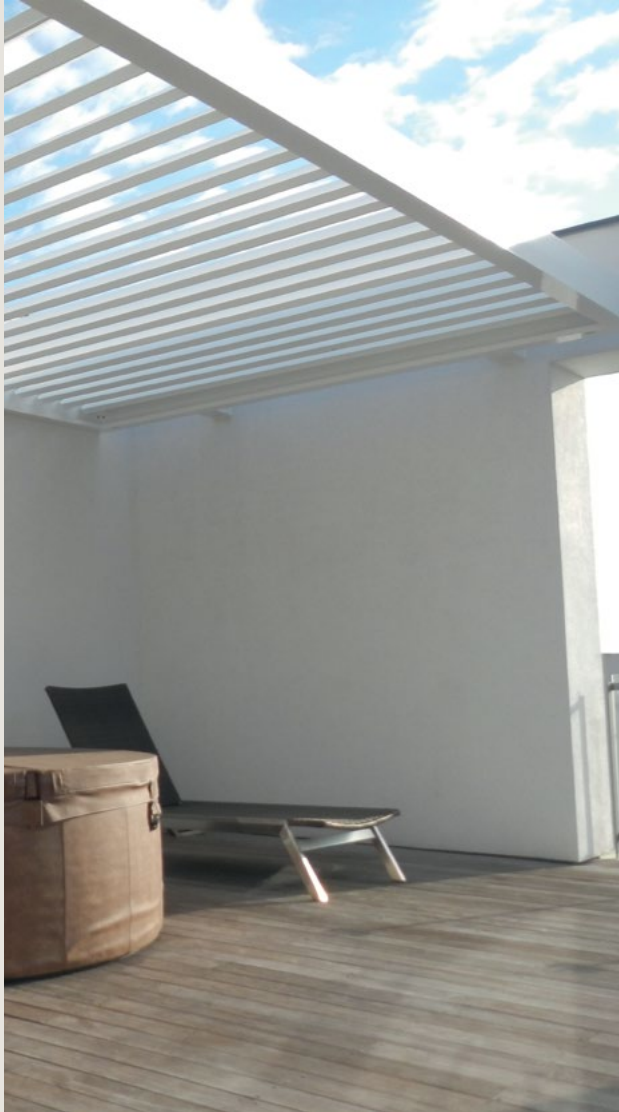

- Maximum pivot dimension: 7000 mm
- Maximum span dimension: 4000 mm (once pivot length > 6055 mm)
- Beam Heat & Sound: NOT possible on the pivot
- Maximum number of Led blades: 3
- Maximum number of glass blades: 5
- Maximum number of Lineo Fix/Heat blades: 3
- Minimum number of water drainage points: three, of which two on the lowest side

Aero Infinity



Specifications

- Aero where 2 roof sections are coupled to the span, without an intermediate beam.
- The blades run beautifully over the 2 roof parts.
- Equipped with 2 motors (1 per roof section).

Conditions

- Dimensions pivot: 7001 - 13500 mm
- Dimension span: max. 4000 mm (as soon as pivot length > 12110 mm)
- Maximum number of Led blades per roof section: 3
- Maximum number of glass blades per roof section: 5
- Maximum number of Lineo Fix /Heat blades per roof section: 3
- Updown Led on the pivot side always runs over the pivot length of the 2 roof sections
- Protecto always runs over the entire pivot length
- Beam Heat & Sound: NOT possible on the pivot

Aero weight

		Total weight (kg) of entire Aero															
		Span															
Pivot	Dimensions in mm	#Blades	1800	2000	2200	2400	2600	2800	3000	3200	3400	3600	3800	4000	4200	4400	4500
	2615	11	145	155	164	175	185	194	204	213	223	233	242	252	261	272	277
	2830	12	154	163	174	185	195	205	215	226	236	246	256	266	278	288	293
	3045	13	162	173	184	194	205	216	227	238	249	259	270	282	293	304	309
	3260	14	171	181	193	204	215	227	238	250	261	273	285	297	308	320	325
	3475	15	180	190	202	214	226	238	250	262	274	287	299	311	323	335	342
	3690	16	188	198	211	223	236	249	261	274	288	301	313	326	339	351	358
	3905	17	197	206	220	233	246	260	273	287	301	314	327	341	354	367	374
	4120	18	205	215	229	243	257	271	285	299	313	327	341	355	369	383	390
	4335	19	214	223	238	252	267	282	297	312	326	341	355	370	384	399	406
	4550	20	222	232	247	262	278	293	309	324	339	354	369	384	400	415	423
	4765	21	230	240	256	273	288	304	320	336	352	367	383	399	415	432	440
	4980	22	239	248	266	282	299	315	332	348	364	381	397	414	431	448	456
	5195	23	247	258	275	292	309	326	343	360	377	394	411	429	446	463	472
	5410	24	257	266	284	302	319	337	355	372	390	409	426	444	462	479	488
	5625	25	265	275	293	311	330	348	366	384	404	422	440	459	477	495	504
	5840	26	274	283	302	321	340	359	378	398	416	435	454	473	492	511	520
	6055	27	282	292	311	331	350	370	390	410	429	449	468	488	507	527	537
	6270	28	291	300	320	341	361	381	402	422	442	463	483	503	524	544	554
	6485	29	288	309	330	351	372	392	413	434	455	476	497	518	539	560	571
6700	30	298	317	339	360	382	404	425	447	468	490	511	533	555	576	587	
6915	31	307	326	348	370	392	415	437	459	481	503	526	548	570	592	603	
7000	32	400	329	352	374	397	419	441	464	486	509	531	554	576	599	610	

Aero snow load

Single Aero

For span lengths < 3625 mm, the load-bearing capacity is determined by the pivot length. For span lengths > 3625 mm, the load-bearing capacity is no longer determined by the pivot dimensions, but exclusively by the span length (blade length) instead.

Maximum snow load single Aero (kg/m ²)																	
Pivot	Dimensions in mm	#Blades	Span														
			1800	2000	2200	2400	2600	2800	3000	3200	3400	3600	3800	4000	4200	4400	4500
	2615	11	300	300	300	300	252	197	156	125	101	82	67	55	45	37	34
	2830	12	300	300	300	300	252	197	156	125	101	82	67	55	45	37	34
	3045	13	300	300	300	300	252	197	156	125	101	82	67	55	45	37	34
	3260	14	300	300	300	300	252	197	156	125	101	82	67	55	45	37	34
	3475	15	300	300	300	300	252	197	156	125	101	82	67	55	45	37	34
	3690	16	300	300	300	300	252	197	156	125	101	82	67	55	45	37	34
	3905	17	300	300	300	300	252	197	156	125	101	82	67	55	45	37	34
	4120	18	300	300	300	300	252	197	156	125	101	82	67	55	45	37	34
	4335	19	300	300	300	300	252	197	156	125	101	82	67	55	45	37	34
	4550	20	300	300	300	300	252	197	156	125	101	82	67	55	45	37	34
	4765	21	300	300	300	276	254	197	156	125	101	82	67	55	45	37	34
	4980	22	300	300	275	251	230	197	156	125	101	82	67	55	45	37	34
	5195	23	300	270	244	223	205	189	156	125	101	82	67	55	45	37	34
	5410	24	264	236	213	194	178	165	153	125	101	82	67	55	45	37	34
	5625	25	232	207	187	170	156	144	133	124	101	82	67	55	45	37	34
	5840	26	204	183	165	150	137	126	117	109	101	82	67	55	45	37	34
	6055	27	181	161	145	132	121	111	103	95	89	82	67	55	45	37	34
	6270	28	222	199	181	166	153	142	133	125	101	82	67	55			
	6485	29	211	190	173	158	146	136	127	119	101	82	67	55			
	6700	30	206	185	168	154	142	132	123	116	101	82	67	55			
	6915	31	200	180	164	150	138	129	120	113	101	82	67	55			
	7000	32	198	178	162	148	137	127	119	111	101	82	67	55			

Tables do not exceed 300 kg/m² as values above this figure are no longer relevant.

Single Aero with additional beam

The static snow load in a symmetrical single Aero structure with an additional beam is shown in the table below.

Maximum snow load single Aero with additional beam (kg/m ²)																									
Pivot	Dimen- sions in mm	# bla- des	Span																						
			1800	2000	2200	2400	2600	2800	3000	3200	3400	3600	3800	4000	4200	4400	4500	4600	4800	5000	5200	5400	5600	5800	6000
	2615	11	2028	1615	1316	1092	919	784	676	589	517	457	406	363	327	295	281	267	243	222	203	187	172	159	147
	2830	12	1872	1491	1214	1007	848	723	624	543	476	421	374	335	301	271	258	246	224	204	187	171	158	146	134
	3045	13	1738	1384	1127	935	787	671	578	503	441	390	347	310	278	251	239	228	207	189	173	158	146	134	124
	3260	14	1622	1291	1051	872	734	626	539	469	411	363	323	288	259	234	222	212	192	175	160	147	135	124	115
	3475	15	1520	1210	985	817	687	586	505	439	385	340	302	270	242	218	207	198	179	164	150	137	126	116	107
	3690	16	1431	1138	926	768	646	550	474	412	361	319	283	253	227	205	195	185	168	153	140	128	118	108	100
	3905	17	1351	1075	874	724	609	519	447	389	340	300	267	238	214	192	183	174	158	144	131	120	111	102	94
	4120	18	1279	1017	828	686	577	491	423	367	322	284	252	225	202	182	173	164	149	136	124	113	104	96	88
	4335	19	1214	966	786	651	547	466	401	348	305	269	239	213	191	172	163	155	141	128	117	107	98	90	83
	4550	20	1156	919	747	619	520	443	381	331	290	256	227	202	181	163	155	147	134	121	111	101	93	85	78
	4765	21	1103	877	713	590	496	422	363	315	276	243	216	192	172	155	147	140	127	115	105	96	88	81	74
	4980	22	1054	838	681	564	474	403	347	301	263	232	206	183	164	148	140	133	121	110	100	91	84	77	71
	5195	23	1009	802	652	540	453	386	332	288	252	222	197	175	157	141	134	127	115	105	95	87	80	73	67
	5410	24	968	770	625	517	435	370	318	276	241	212	188	168	150	135	128	122	110	100	91	83	76	70	64
	5625	25	931	739	601	497	417	355	305	265	231	204	180	161	144	129	122	116	105	96	87	79	72	66	61
	5840	26	895	711	578	478	401	341	293	254	222	195	173	154	138	124	117	111	101	91	83	76	69	63	58
	6055	27	863	685	557	460	386	328	282	245	214	188	166	148	132	119	113	107	97	88	80	73	66	61	56

ACCESSOIRES



Comfort pack		Back order	
Fixscreen + Lineo Led	-	-	-
Side inserts			
Integrated Fixscreen	-	-	-
Algarve Fixscreen	-	-	-
Lapure Fixscreen	-	-	-
Triangle	-	-	-
Loggia sliding panels	-	-	-
Loggiascreen Canvas sliding door	-	-	-
Glass sliding panels	-	-	-
Linius wall*	-	-	-
Linarte wall*	-	-	-
Outdoor curtains	-	-	-
Comfort			
Lighting			
Lineo Led	✓	-	-
UpDown Led	✓	-	✓
Colomno Led	-	-	-
Lapure Led	-	-	-
Comfort and design			
Beam Heat & Sound	✓	-	✓
Lineo Luce	✓	-	✓
Lineo Fix	✓	-	-
Lineo Heat	✓	-	-
Waterproof wall mounting	-	-	-
Protecto protective profile	✓	-	✓
Automation			
Wind sensor	✓	-	✓
Rain sensor	✓	-	✓
Sun sensor	-	-	-



Styling		Back order
Classic Line	-	-
Wooddesign roof blades	✓	-
Columns		
Extra column	-	-
Shifted column	-	-
Adjustable wall column	-	-

CERTIFICATES & TESTING

Water tests

Water resistance and water drainage are tested using a spray installation that mimics rain. For example, we check the flow rate that our patio covers can drain and how this drainage can be optimised.

Aero can drain an amount of water equivalent to a rain shower with an intensity of 120 mm/h that last up to two minutes maximum. This type of rainfall occurs on average once every ten years in Belgium (see Belgian rain statistics: NBN B 52-011 standard).

Load-bearing capacity

Patio covers are subjected to various external forces (e.g. snow). The load-bearing capacity of our patio covers is determined using static strength calculations carried out by our engineers and validated through internal tests. The basic principle is that the structure is allowed to bend by 1/200th of its longest dimension without any permanent deformation.

The load-bearing capacity of Aero is dependent on the basic structure and the surface area. The diagram indicates the load-bearing capacity of our patio covers depending on their span and pivot dimensions.

	Load-bearing capacity against collapse (6 × 4 m)
Aero, Aero Skye & Aero Canvas	100 kg/m ²

CE – DoP documents

- CE / UKCA / DoC / DoP / ETA



Certificates

- REACH / seaside/coastal powder coating guarantee
- RoHS / AluEco
- VMRG sun protection

Declarations

- Declaration of material codes
- Declaration of powder coating
- Declaration of anodisation layer thickness
- Declaration of glass properties
- Declaration of fire resistance / reaction
- Declaration of endurance cycles
- Declaration of asbestos
- Declaration of UV resistance / gtot + others

Test reports – calculations

- Environmental statement (recycled aluminium)
- Anchoring requirements
- Wind (load) testing / verification certificate

Wind guarantee of roof with blades closed	up to 120 km/h
Wind guarantee of roof with blades open	/*
Max. wind speed for roof operation	up to 50 km/h
Water drainage flow	120 l/m ² /h

* We recommend against opening the blades in high winds > 50 km/h, as there is a risk that the blades may start vibrating and operating the blades is only permitted up to 50 km/h.

DETERMINATION OF OCCURRING FORCES

For example: Aero measuring 6000 × 4000 mm

Blade load (net weight + snow load) = 1.24 kN/m².

For a roof surface area of 6000 × 4000 mm, that makes: 6 × 4 × 1.24 = 27.76 kN.

The net weight of the frame, consisting of two span and two pivot profiles, is: 2 × (5.714 kg/m* × 6 + 3.910 kg/m** × 4) = 99.85 kg = 0.979 kN***.

Total load on 6 × 4 m Aero = 27.76 + 0.979 = 28.74 kN.

Total load per bolt = 28.74 kN / number of bolts.

* weight of pivot profile/m

** weight of span profile/m

*** 1 kg = 9.80665 N

Bolt grades	4.6	5.6	6.8	8.8	10.9
Flow limit	240	300	480	640	900
Tensile strength	400	500	600	800	1000
Sliding factor	0.6	0.6	0.5	0.6	0.5

	Hole diameter d0 (mm)	Shank cross-section (mm ²)	Span cross-section (mm ²)
M12	13	113	84,3
M16	18	201	157
M20	22	314	245
M24	26	452	352

Bolt shear load

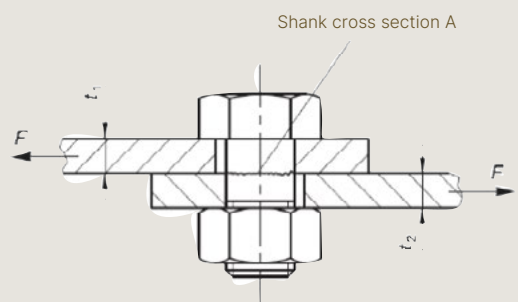

$$F_{v,Rd} = \frac{(\alpha_v \cdot f_{u,b} \cdot A)}{\gamma_{m2}}$$

Example: M12 grade 4.6 bolt → maximum shear force on bolt = (0.6 * 400 * 84.3) / 1.25 → 16.19 kN.

$F_{v,Rd}$ = maximum permissible shear force
 $\alpha_v = 0.6$ → safety factor for shearing
 $f_{u,b}$ = nominal tensile strength
 A = span cross-section
 γ_{m2} = partial safety factor = 1.25

CONFIGURATION

Type

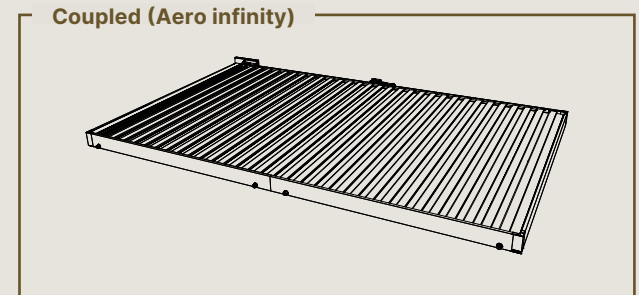
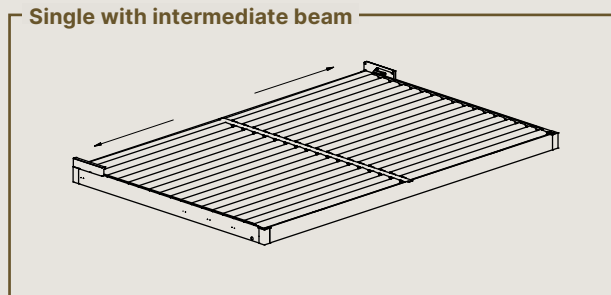
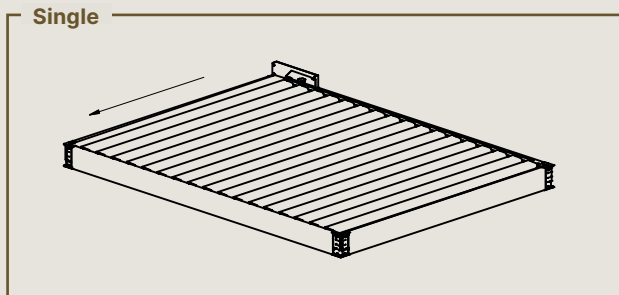

Construction method

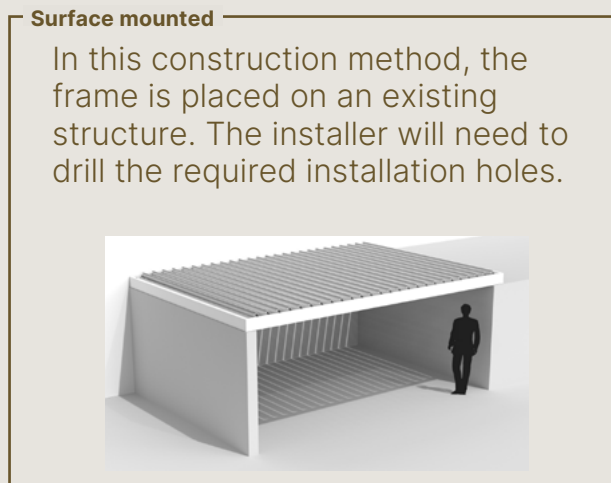
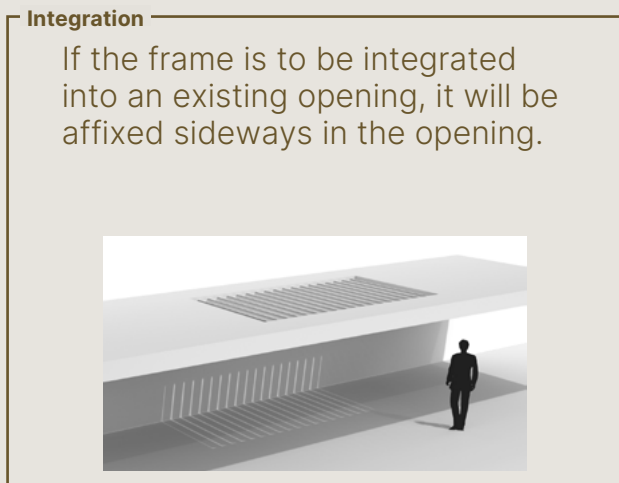

Dimensions

The **span** length is always to be specified with **mm** precision.

You can then specify a **pivot** length based on either the **blade pitch** or with **mm** precision.

Depending on whether you go by the blade pitch or specify a precise mm length, there is an important aesthetic difference for the pivot. If the pivot is produced with mm precision, we will use the Camargue's residual blade. If you specify a pivot dimension based on the blade pitch, there will not be an extra residual blade next to the fixed blade in which the controls are located.

The drawings below provide further clarification on this difference.

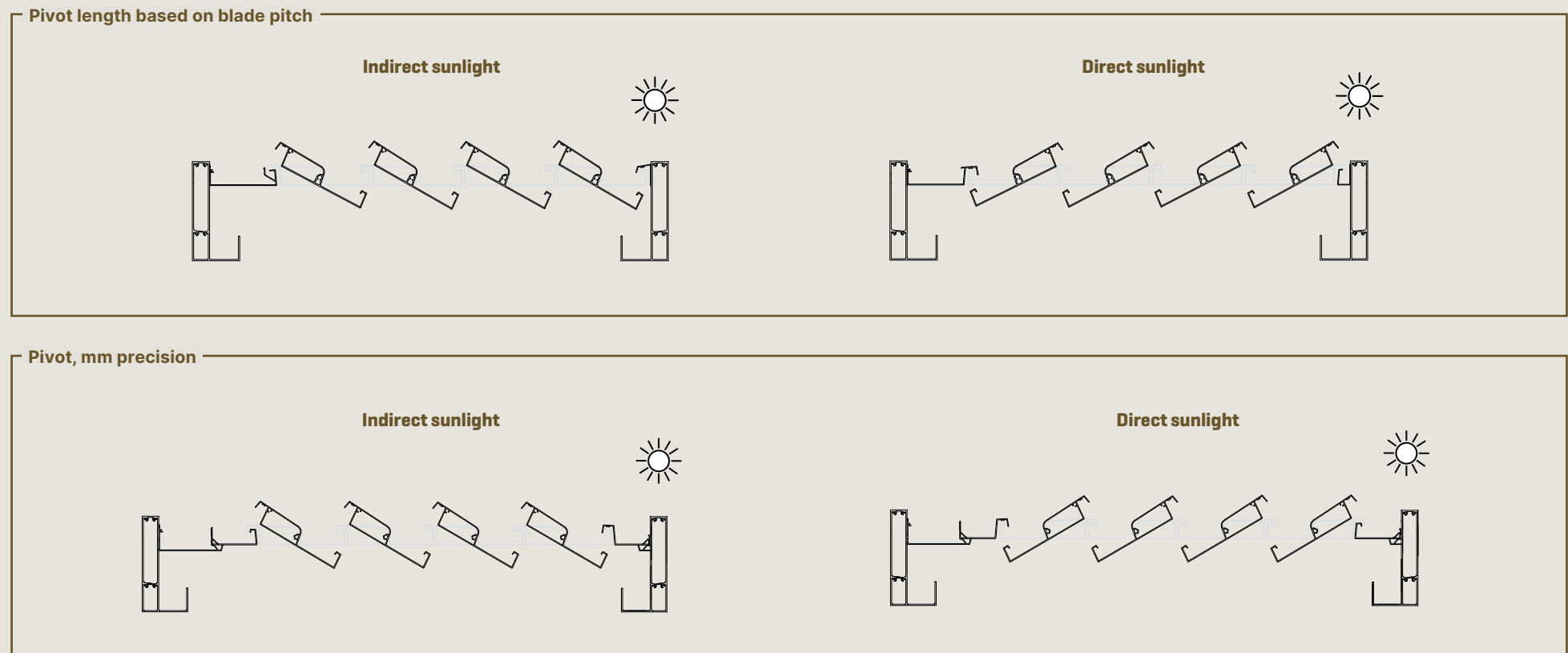

Outer corner finishing cover

When ordering, please specify the construction situation for each span and pivot side.

Depending on which one of the two construction situations you opt for, there is also a significant difference in terms of the finishing cover supplied for the outer corner.

- Surface mounted: includes finishing cover for the side in question
- Integrated: no finishing cover for the side in question

Note: If you still want finishing caps on the outer corners for integration, you can indicate this during the Rio configuration of the Aero.

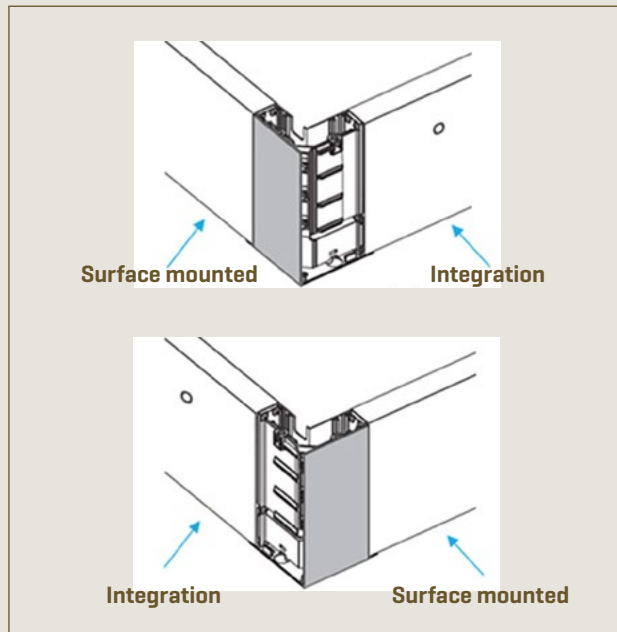

Bottom finishing cover

The bottom finishing cover protrudes a few mm from the underside of the structure.

If you place Aero on top of another structure, you have the option of doing so without the bottom finishing cover. That way, the bottom of the profiles fit nicely against the support structure.

In the **example to the side**, the bottom finishing cover cannot be omitted because the bottoms of the profiles are also partially visible. However, this does not result in a perfect connection.

If the bottom of the frame profiles is to be finished with another material and will ultimately no longer be visible, there is no need to place a finishing cover on the bottom corners.

If you have a situation where you wish to install the outer corner cover, but do not have a bottom corner cover, you must first install an **additional bracket**. This will allow you to install the outer corner cover without the bottom corner cover.

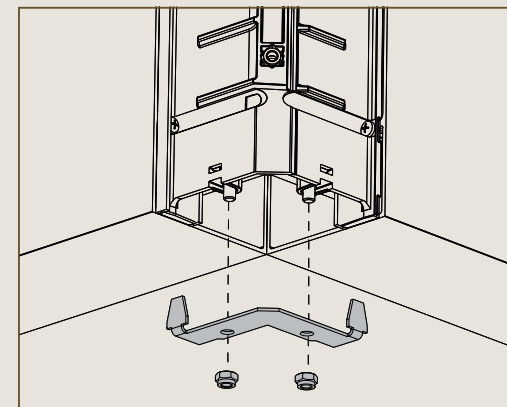
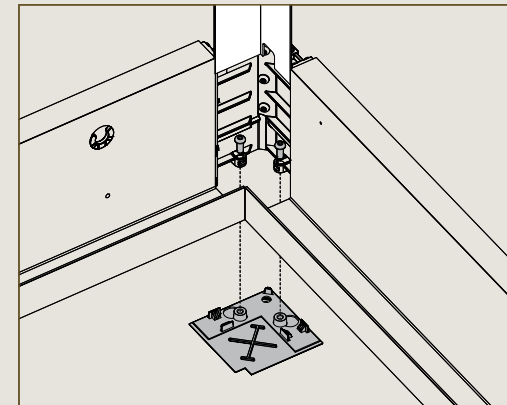
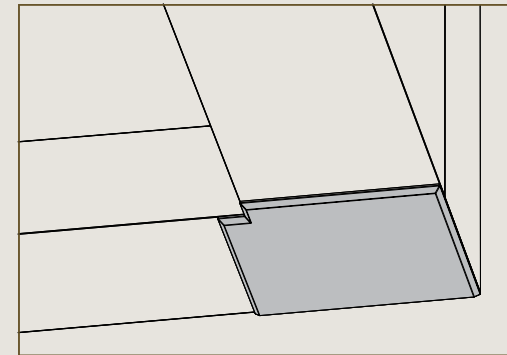

Wall connection profile

For the Span (S) and Pivot (P) sides that were selected as 'integration' (construction method), an additional option can be selected.

For these sides, the basic Span/Pivot beam can be replaced by a variant with a wall connection profile.

- Provides an easy (EPDM) seal between Aero and the structure in which Aero is mounted.
- Easy sealing also on the motor, because the motor moves up 10 mm. No EPDM seal is required under the motor anymore.
- This results in a different (higher) driving profile.
- This results in a higher motor cover (150 mm instead of 130 mm).
- Take this into account when installing under a roof overhang.
- The top corner cover is also fitted with a wall connection profile

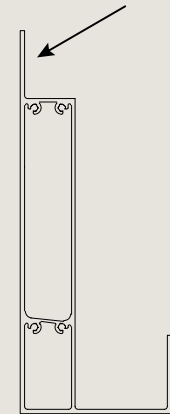

Basic profile variant with wall connection profile

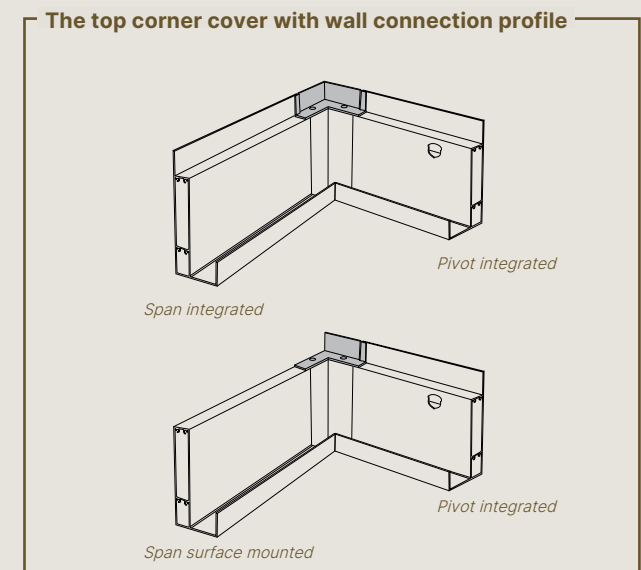
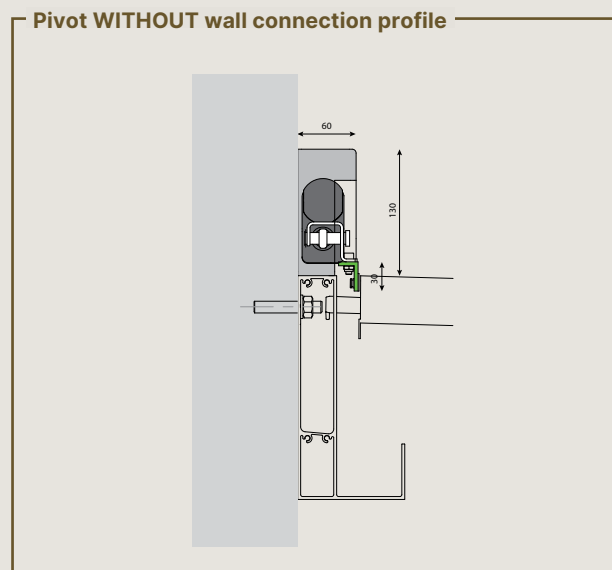
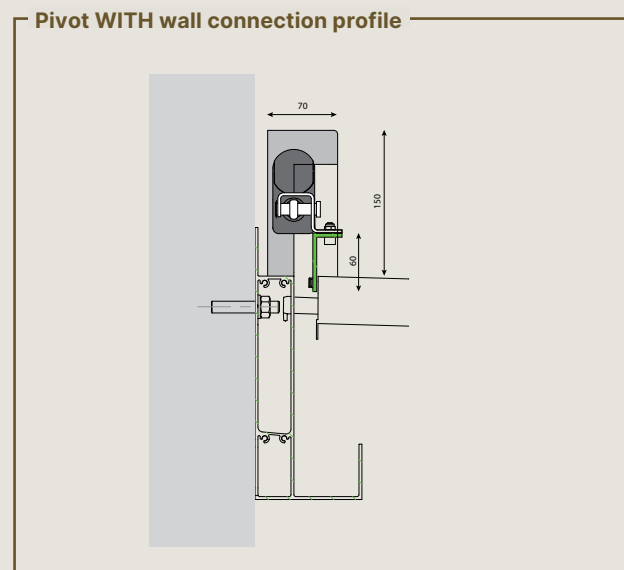

Profiles

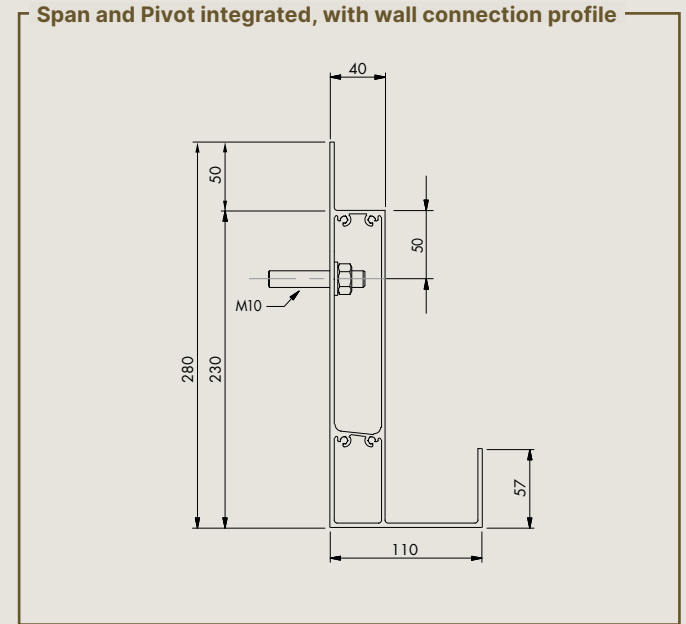
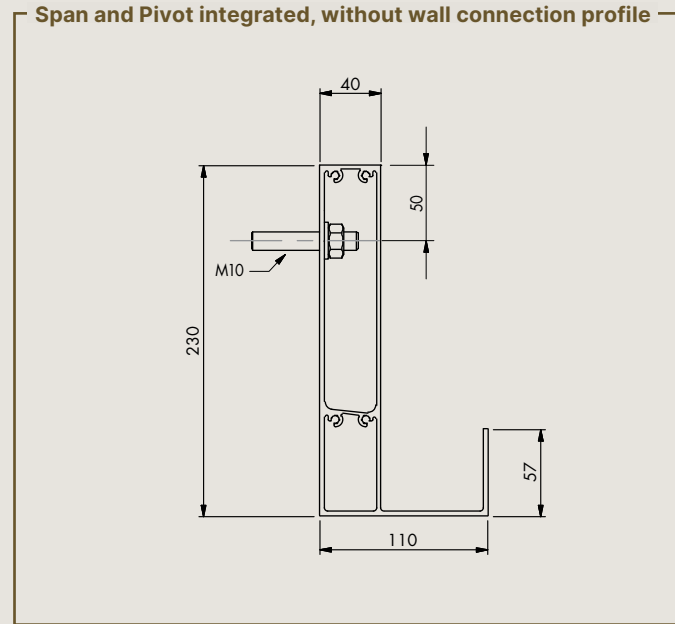
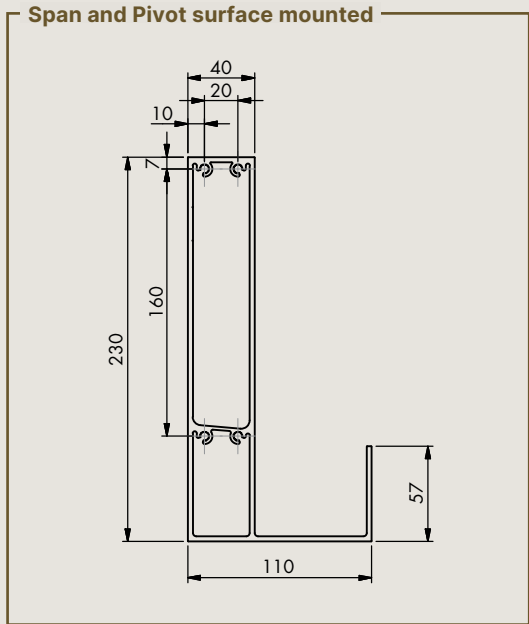
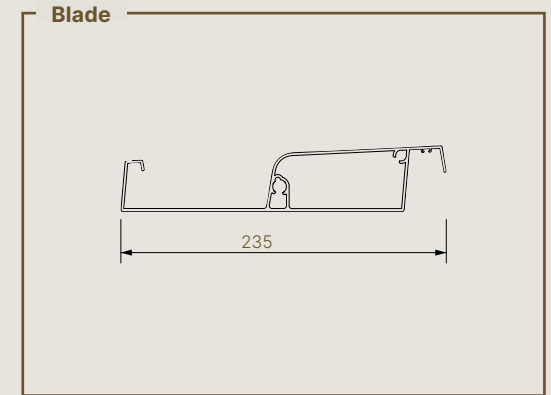
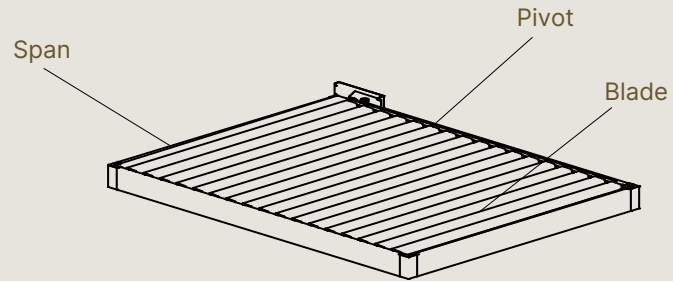

Motor control

The blades are driven by a linear motor. This motor is visible on the Aero structure. It is controlled via RTS or io, an external Somfy control platform that is implemented in the motor control unit.

The motor sits on top of the frame and is covered with a powder coated aluminium cover in the colour of the structure.

The location of the motor can be chosen on pivot 1 or pivot 2 and is always on this pivot on the side of span 2 (side with the fixed blade).

Please note: water drainage must always be fitted on the low pivot side.

The motor position is fixed in a joined cover. Both motors are always on the outer pivot beams.

Power supply

Check to see where the motor will be installed. Arrange a power cable closest to the motor.

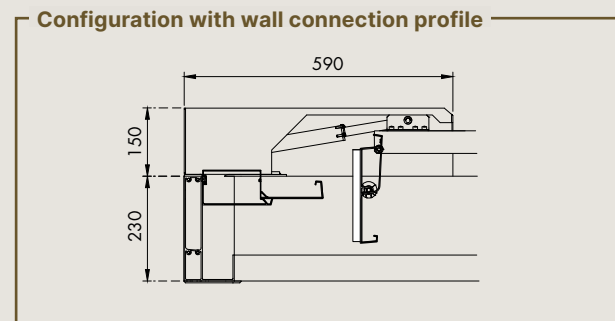
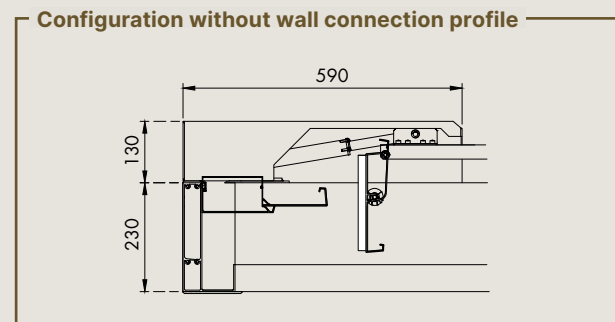
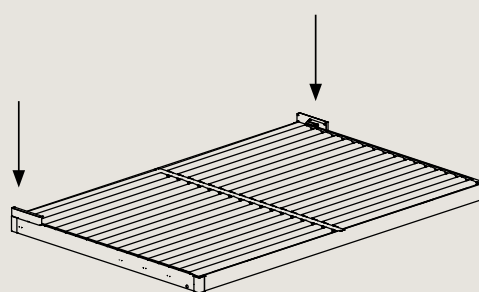
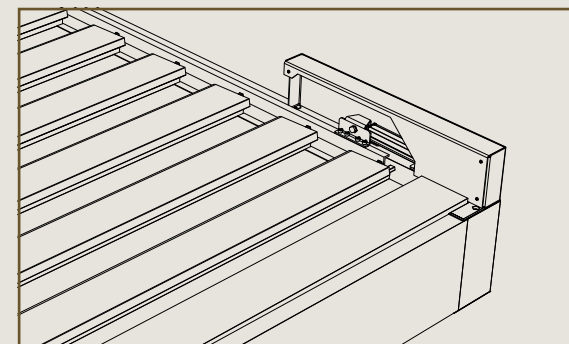
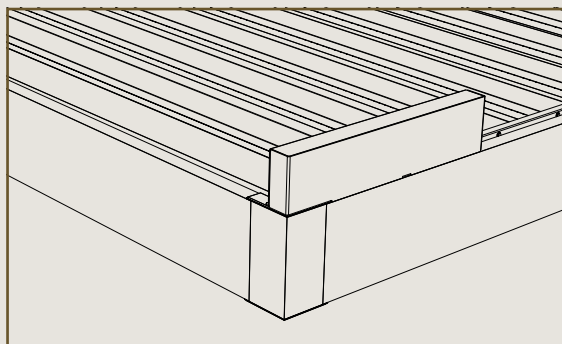

Blade orientation

Sun Protection : keep light out when open

Indirect sunlight

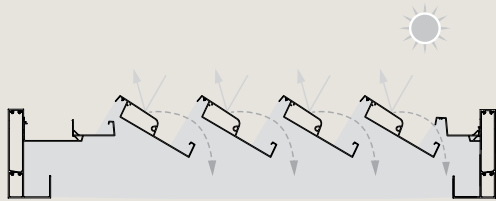

Roof closed

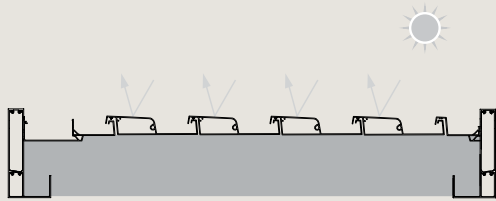

Direct sunlight

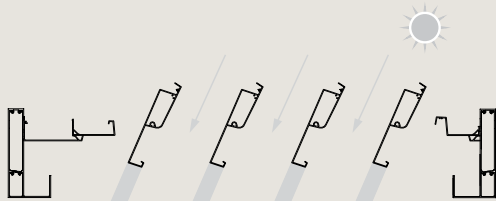

Light allowed to enter when open

Direct sunlight

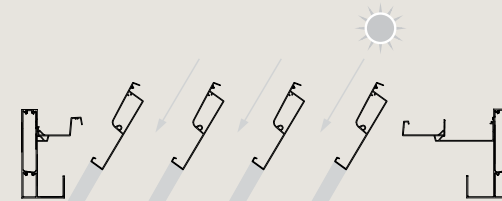

Roof closed

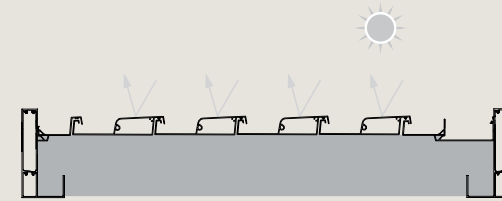

Indirect sunlight

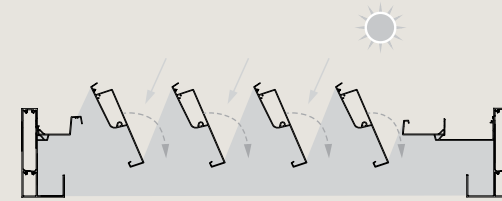

Installation

For Aero, you must select the construction situation for each side (span (S) –pivot (P)) when ordering. You can choose between surface mounted or integrated. Side fixation holes will be applied if you select **'integrated'**. **No** side fixation holes will be applied if you select **'surface mounted'**.

The number and position of fixation holes on each side varies according to the size of the structure. You can find out the position of the holes using a calculation tool (Excel file), so you can adapt the roof structure beforehand.

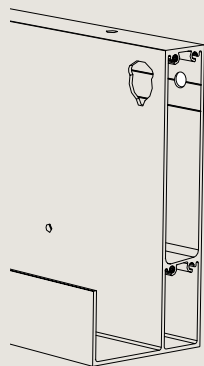

Fixation hole when choosing 'integrated'

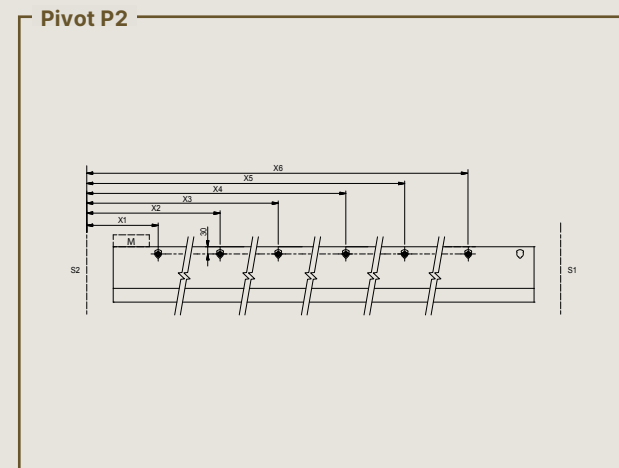
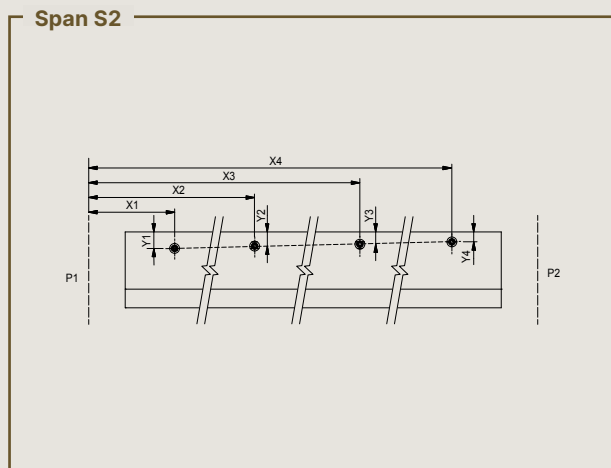
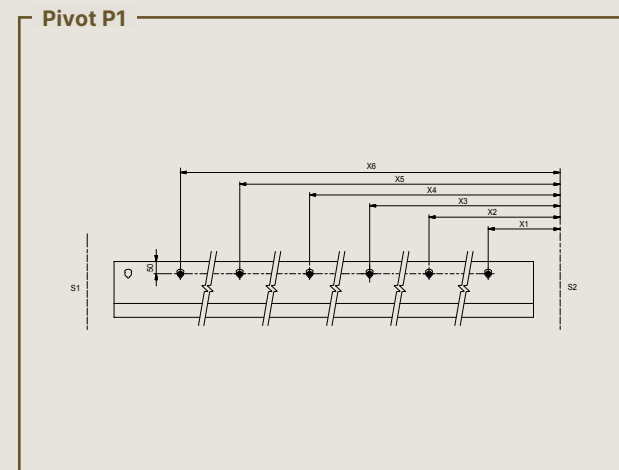
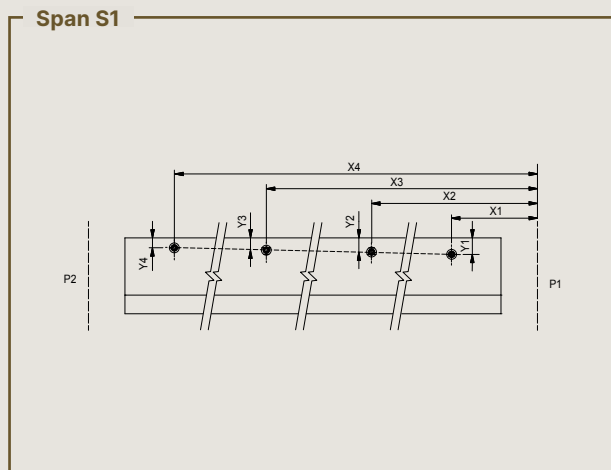

- Pivot side: the fixation holes are level with the blade axles, meaning they will not be visible at a later stage.
- Span side: the fixation holes are level with the fixed blade, meaning they will not be visible at a later stage.

The fixation holes in the structure are 12 mm in diameter, allowing an M10 bolt can be threaded through.

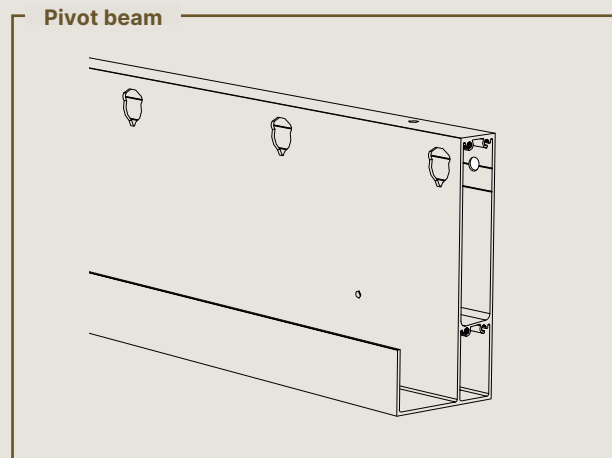

Number of fixation holes on pivot side	
0 – 2000	2 x M10
2001 – 3000	3 x M10
3001 – 4000	4 x M10
4001 – 5000	5 x M10
5001 – 6055	6 x M10
6056 – 7000	7 x M10

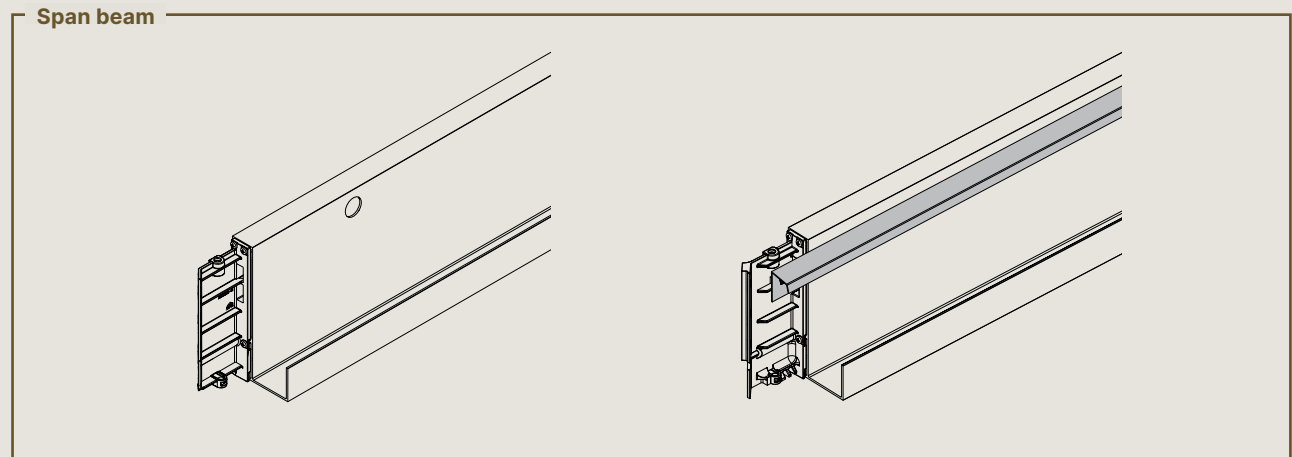

Water drainage

Water drainage direction

The blades are double-walled, with part serving as a gutter. The blades sit at an angle of 2 cm. From the wide blade gutter, water will mainly drain to the lowest side and flow into the structure's integrated gutters. The structure is fitted with an integrated gutter all around.

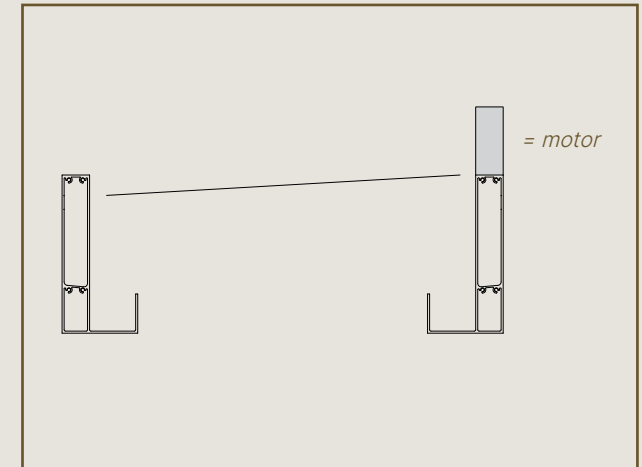
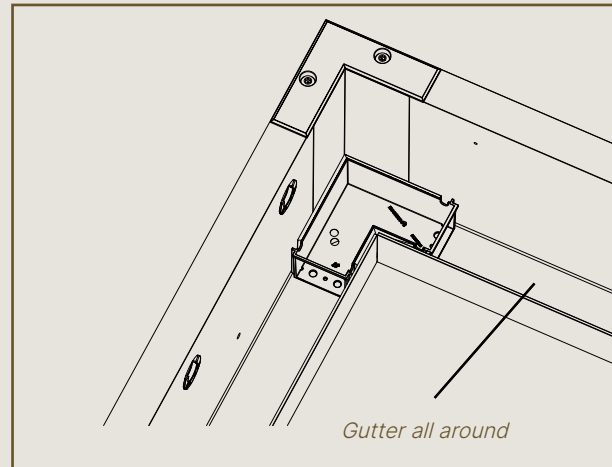
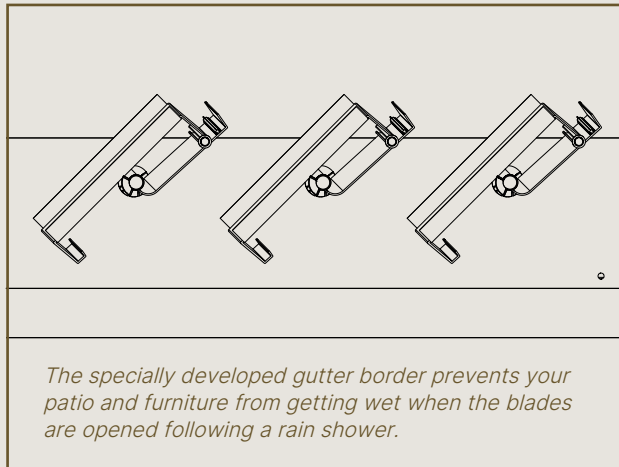

The water drainage direction of the blades is away from the motor side. Upon request, however, this direction can also be towards the motor side. This will result in a different driving profile being fitted.

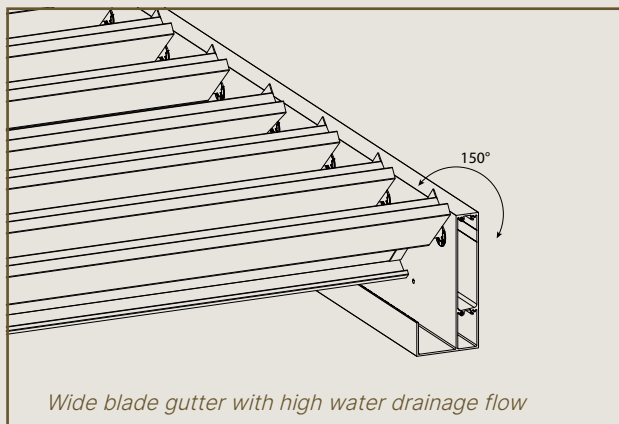

Water drainage types

Water drainage can occur in three ways:

- Through the gutter
- In the corner
- Sideways

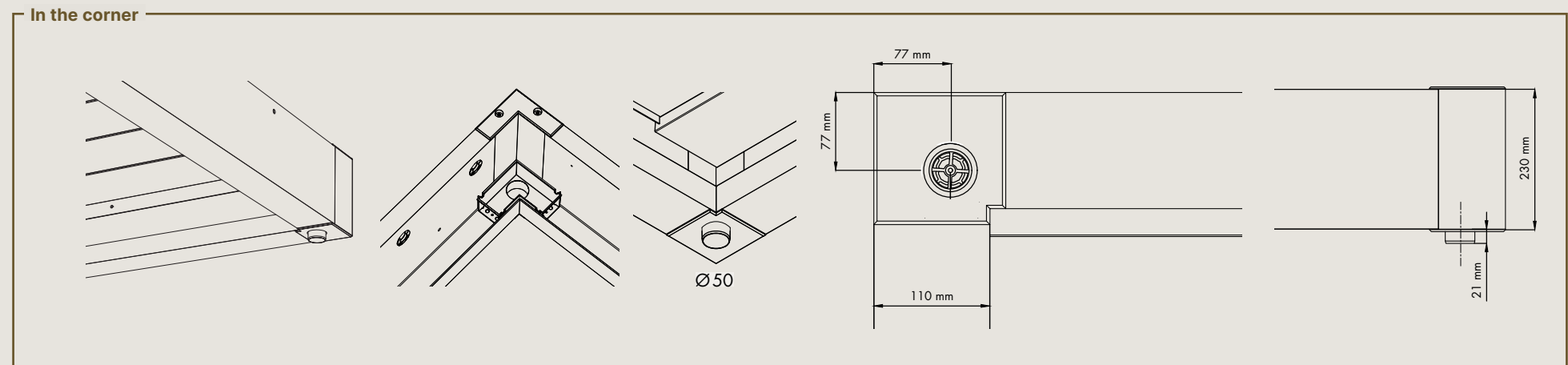
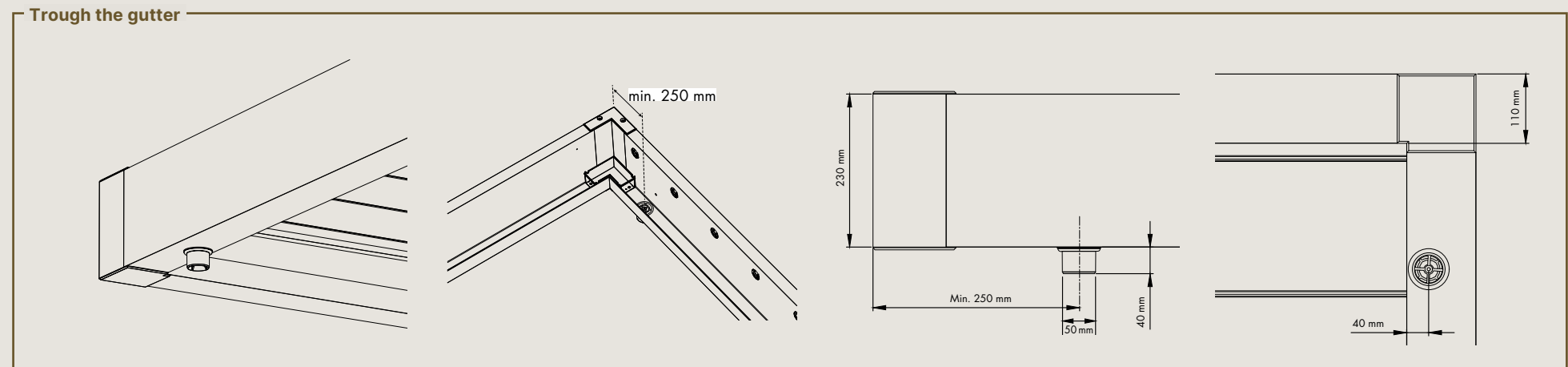

Sideways

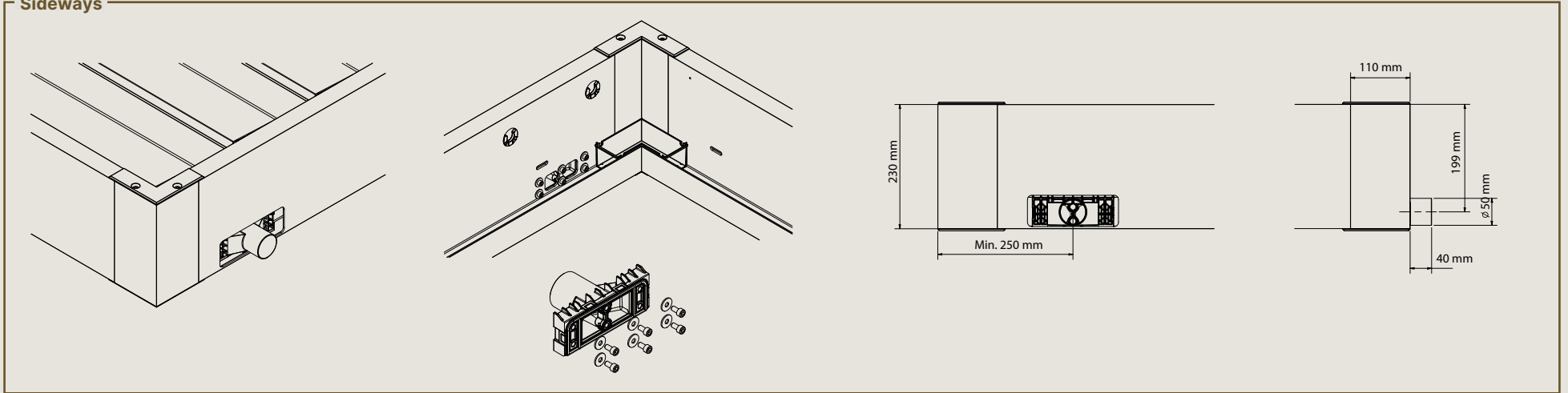

Number of water drainage points

Surface area < 16 m²

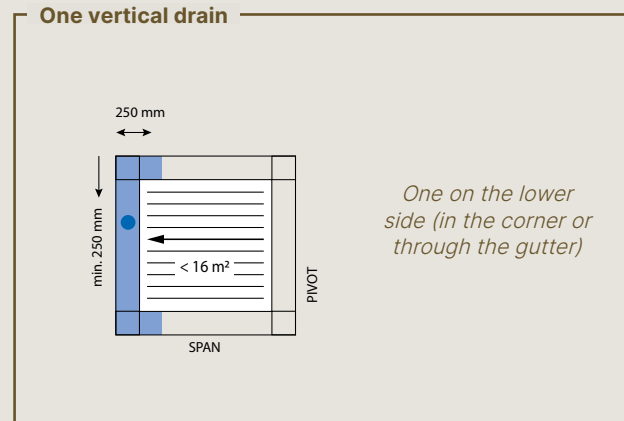

Surface area > 16 m²

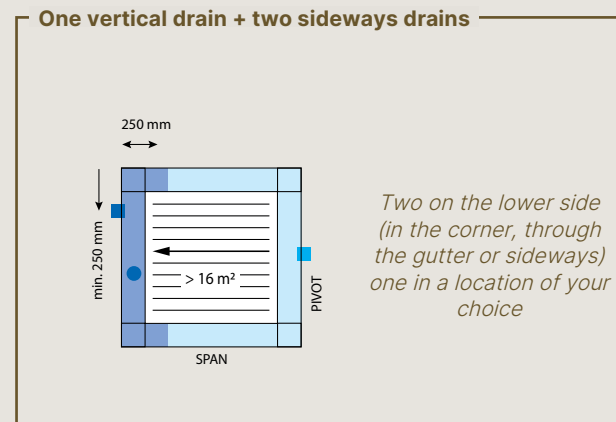
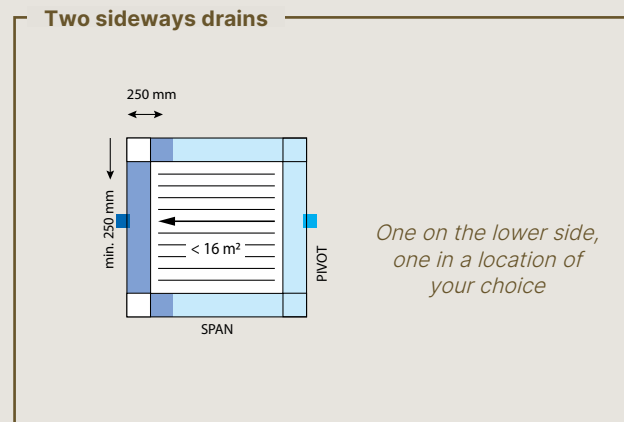
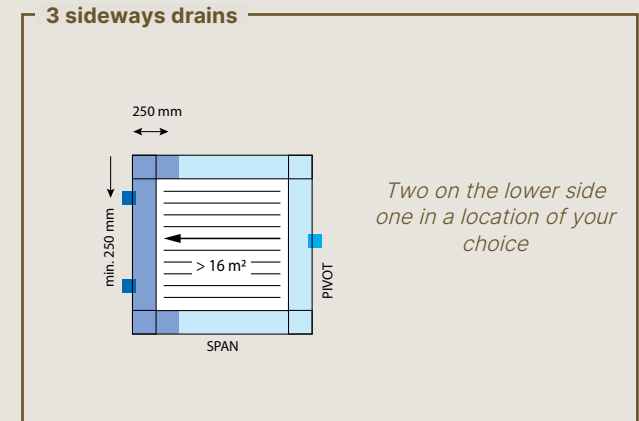
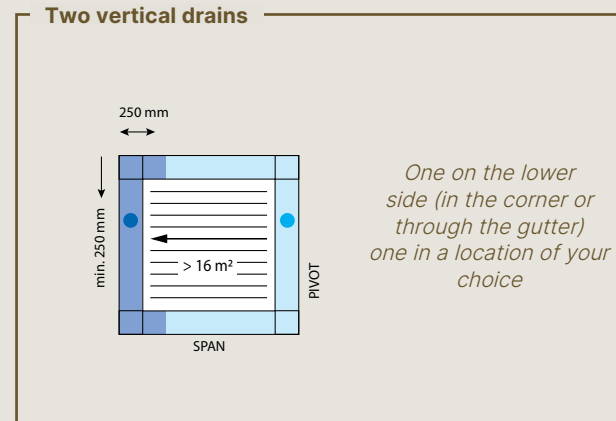

Note: With Aero infinity, the area is considered per roof section (Area of 1 roof section = span x total pivot / 2)

INSTALLATION

Against exterior plastering, via fixation to additional mounting blocks

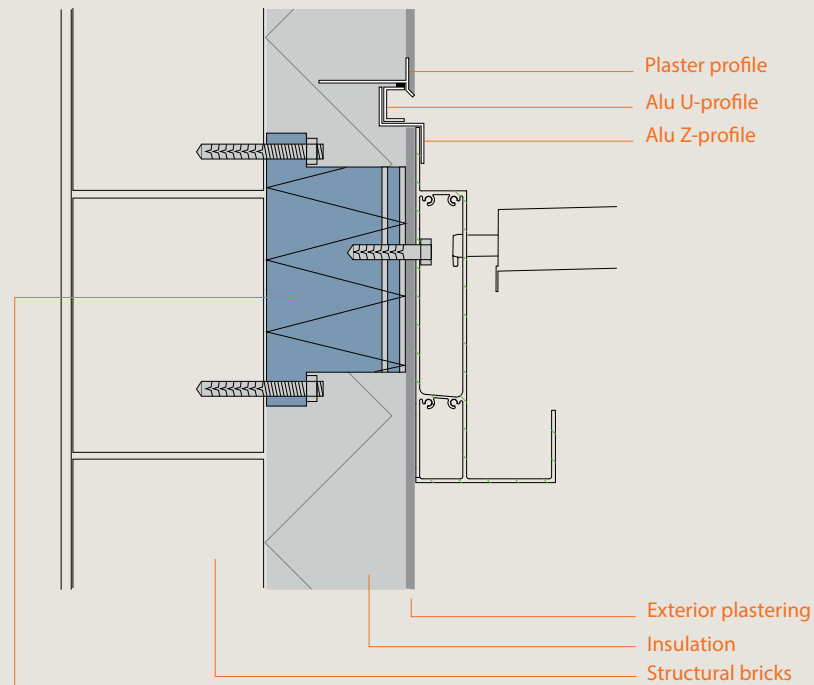

StoFix UMP-ALU-TR
Polyurethane mounting block
with integrated steel brackets



Against façade bricks, via fixation to interior wall

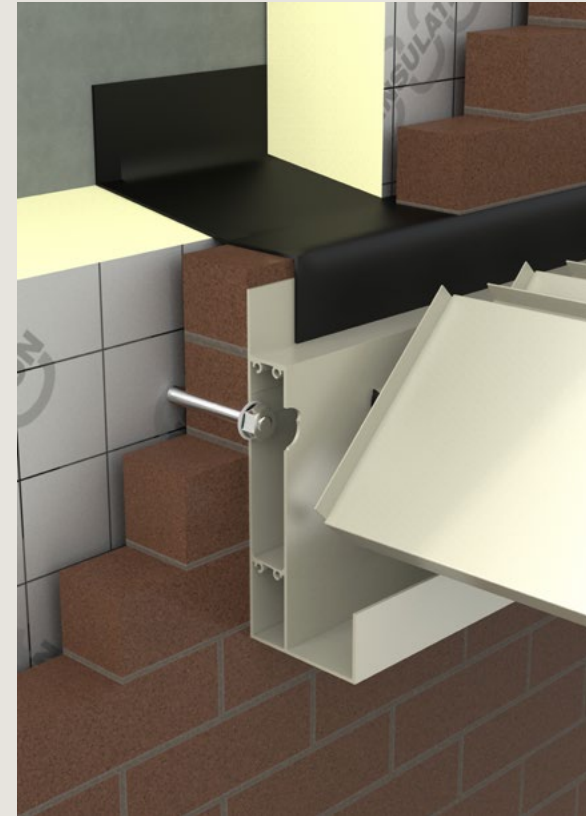
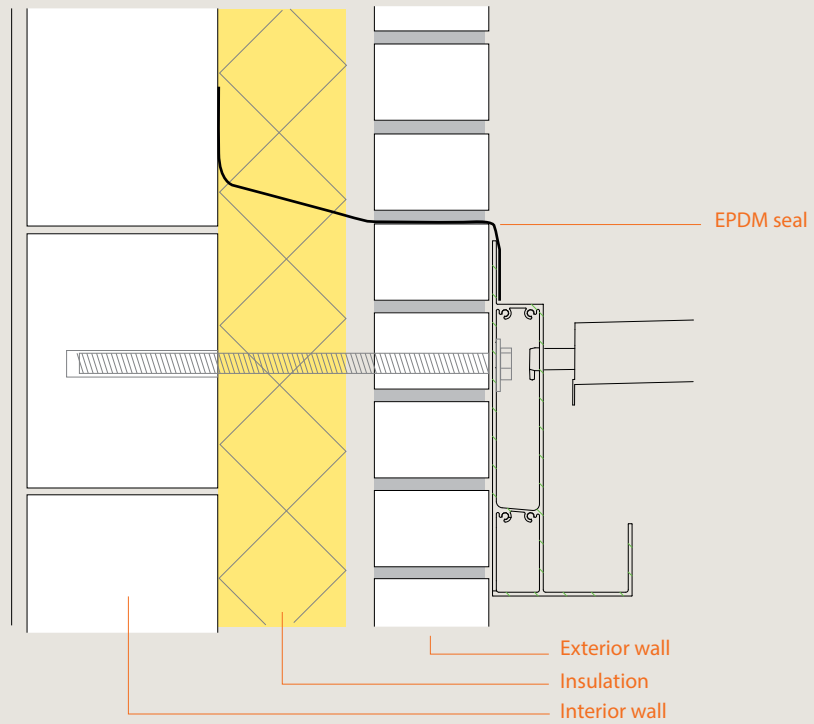

Against a metal IPE profile, via direct fixation

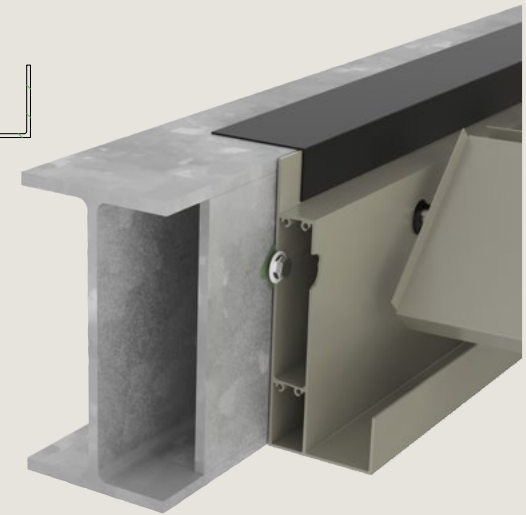
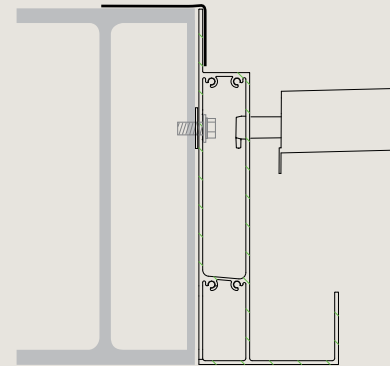
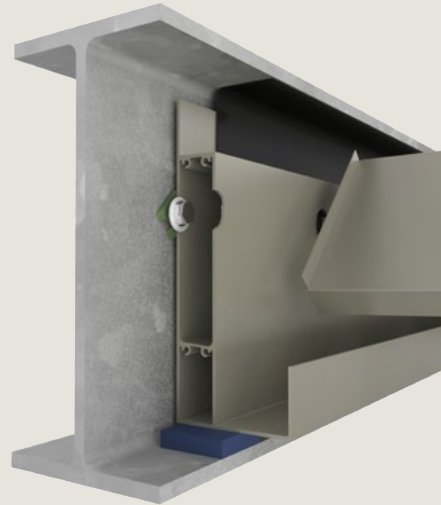
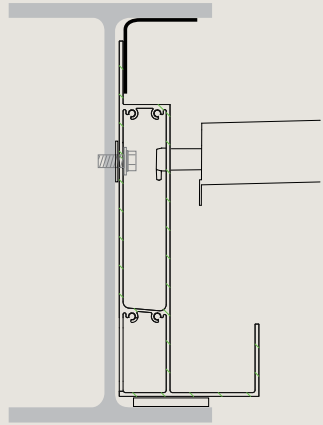

Against a metal UPN profile, via direct fixation

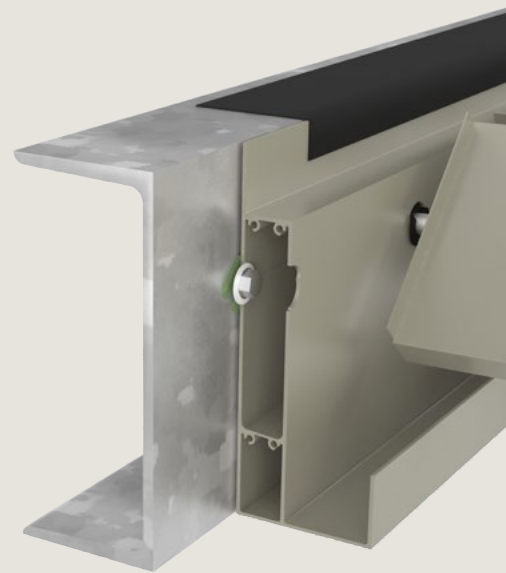
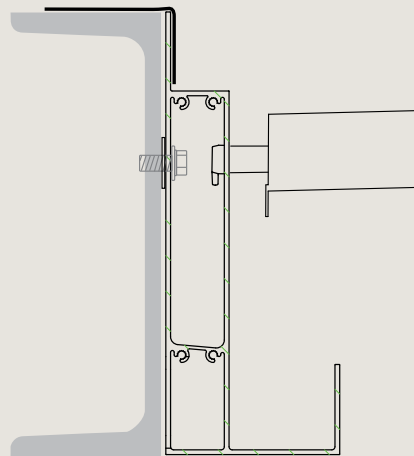

Against a non-insulated wooden structure, via direct fixation

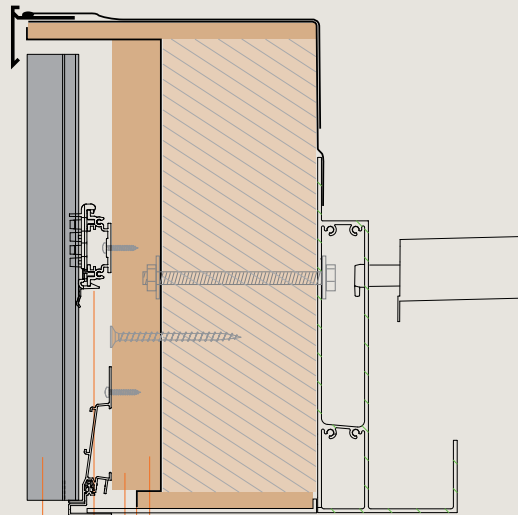

- Basic wooden construction
- Vapor-permeable foil
- Vertical wooden supports
- Horizontal Linarte supports
- Linarte cladding



On a flat roof, via fixation to additional metal mounting bases

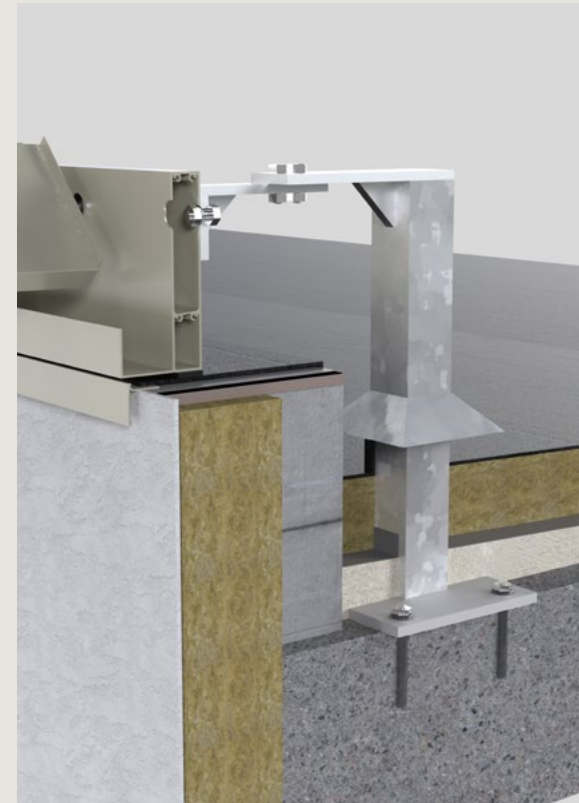
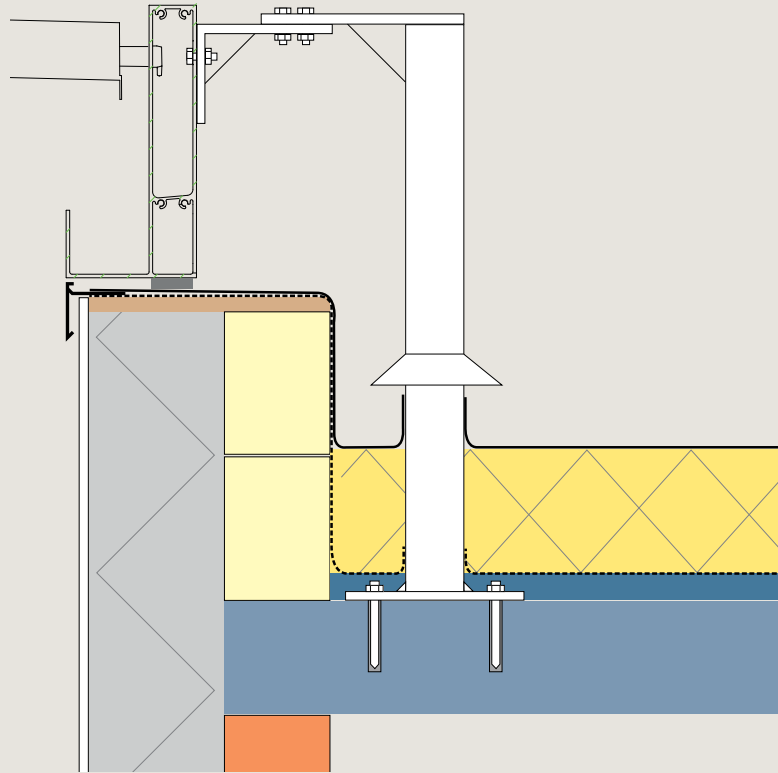

OTHER TOOLS

Want to find out more? Visit the Professional Portal on our website (www.renson.net) to access the following tools.

- Technical drawings
- Training documents
- Installation manual
- User manual
- [Digital photo book & social media](#)
- ...

